

Joining Methods

Molding one part vs. separate components

A major advantage of molding plastics parts is that you can now mold what were previously several parts into one part. These include many of the functional components and many of the fasteners needed to assemble the molded part to other parts. However, due to the limitations of the mold and the process, functional requirements, and/or economic considerations, it is still sometimes necessary to mold various components separately and then assemble them together.

Tolerances: fit between parts

Punched and machined parts can be made to tighter tolerances than molded parts because the large shrinkage from the melt to the solid state make sizing less predictable. In many cases, the solidification is not isotropic, so that a single value of mold shrinkage does not adequately describe the final dimensions of the parts.

Fit between plastics parts

- If the two plastics parts are made of the same material, refer to the tolerance capability chart supplied by the material supplier.
- If the two parts are of different material families or from different suppliers, add 0.001 mm/ mm of length to the tolerances from the supplier's tolerance capability charts.
- If the flow orientations are strong, the isotropic shrinkages will require adding 0.001 mm/ mm length to the overall tolerances of the parts.
- Add steps, off-sets, or ribs at the joint line of the two parts to act as interrupted tongue-and-groove elements to provide alignment of the two parts and ease the tolerance problem on long dimensions (see [Figure 1](#)).



Butt Joints Are Difficult To Align



Matching Tongue and Groove Align Two Parts

FIGURE 1. Matching half-tongue and groove align the two parts edges, within normal tolerances.

Fit between plastics parts and metal parts

Make sure that the joint between the plastic and metal allows the plastic part to expand without regard to the expansion of the metal part.

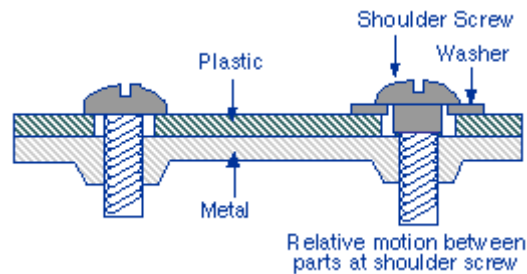

FIGURE 2. Design the joint between plastic and metal to allow for greater thermal expansion and contraction of the plastic. This includes use of shouldered fasteners and clearance between the fastener and the plastic.

Press-fit joints

Simple interference fits can be used to hold parts together. The most common press-fit joint is a metal shaft pressed into a plastics hub. A design chart recommended by the resin suppliers or interference formula can be used to design a press-fit joint at a desirable stress, so the parts will not crack because of excessive stress or loosen because of stress relaxation.

Interference chart

[Figure 3](#) plots the maximum interference limits as a percentage of the insert shaft diameter. Note that this chart is material specific and the maximum interference limit depends on the shaft material and the diameter ratio of the hub and insert. The recommended minimum length of interference is twice the insert diameter.

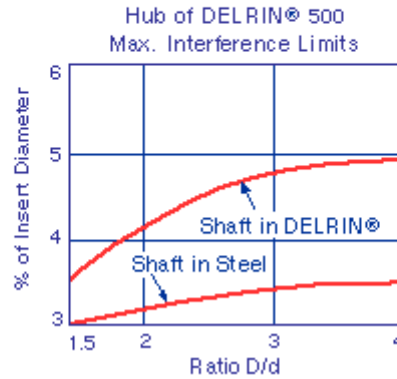
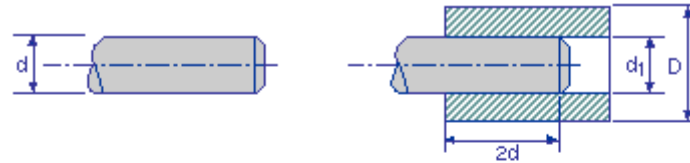

FIGURE 3. Maximum interference limits, pressing a metal shaft into a plastics hub. These curves are specific to the material. The max. interference limit ($d - d_1$) as a percentage of the insert diameter, d , depends on the shaft material and the diameter ratio of the hub and insert (D/d). The recommended minimum length of interference is twice the insert diameter, $2d$.

Interference formula

If the relevant design chart is not available, the allowable interference (difference between the diameter of the insert shaft, d , and the inner diameter of the hub, d_1 , see [Figure 3](#)) can be calculated with the following formula.

$$I = \left(\frac{S_d \times d}{W} \right) \times \left[\left(\frac{W + \nu_h}{E_h} \right) + \left(\frac{1 - \nu_s}{E_s} \right) \right]$$

$$W = \frac{1 + \left(\frac{d}{D} \right)^2}{1 - \left(\frac{d}{D} \right)^2}$$

where:

- I = diametrel interference ($d - d_1$), mm
- S_d = design stress, MPA
- D = outside diameter of hub, mm
- d = diameter of insert shaft, mm
- E_h = tensile modulus of elasticity of hub, MPa
- E_s = modulus of elasticity of shaft, MPa
- ν_h = Poisson's ratio of hub material
- ν_s = Poisson's ratio of shaft material
- W = geometry factor

Tolerance

Check that tolerance build-up does not cause over-stress during and after assembly and that the fit is still adequate after assembly.

Mating metal and plastic parts

Do not design taper fits between metal and plastics parts, because stress cracking will occur from over-tightening.

Snap-fit joints

Snap-fit joints rely on the ability of a plastics part to be deformed, within the proportional limit, and returned to its original shape when assembly is complete. As the engagement of the parts continues, an undercut relieves the interference. At full engagement, there is no stress on either half of the joint. The maximum interference during assembly should not exceed the proportional limit. After assembly, the load on the components should only be sufficient to maintain the engagement of the parts.

Snap-fit joint designs include:

- [Annular snap-fit joints](#)
- [Cantilever snap joints](#)
- [Torsion snap-fit joints](#)

Annular snap-fit joints

This is a convenient form of joint for axis-symmetrical parts. You can design the joint to be either detachable, difficult to disassemble, or inseparable, depending on the dimension of the insert and the return angle.

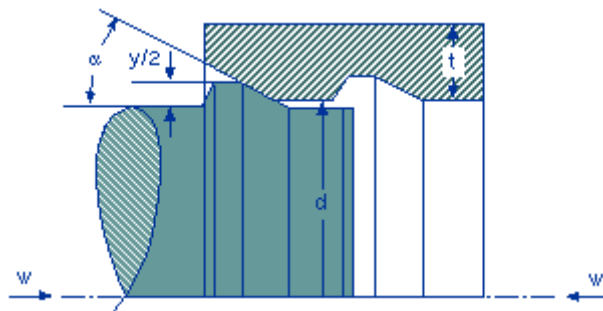

FIGURE 4. Typical annular snap-fit joint. The assembly force, w , strongly depends on the lead angle, α , and the undercut, y , half of which is on each side of the shaft. The diameter and thickness of the hub are d and t , respectively.

Hoop stress

[Figure 5](#) demonstrates that the outer member (assumed to be plastic) must expand to allow the rigid (usually metal) shaft to be inserted. The design should not cause the hoop stress, σ , to exceed the proportional limit of the material.

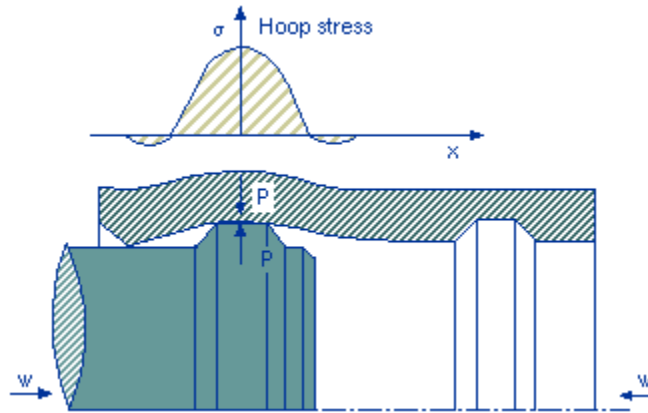

FIGURE 5. Stress distribution during the joining process.

Permissible deformation (undercut)

The permissible deformation (or permissible undercut, y , shown in [Figure 4](#)) should not be exceeded during the ejection of the part from the mold or during the joining operation.

▶ Maximum permissible strain

The maximum permissible deformation is limited by the maximum permissible strain, ϵ_{pm} and the hub diameter, d . The formula below is based on the assumption that one of the mating parts is rigid. If both components are equally flexible, the strain is half, i.e., the undercut can be twice as large.

$$y = c_{pm} \times d$$

▶ Interference ring

If the interference rings are formed on the mold core, the undercuts must have smooth radii and shallow lead angles to allow ejection without destroying the interference rings. The stress on the interference rings (see the equation above) during ejection must be within the proportional limit of the material at the ejection temperature. The strength at the elevated temperature expected at ejection should be used.

Cantilever snap joints

This is the most widely used type of snap-fit joint. Typically, a hook is deflected as it is inserted into a hole or past a latch plate. As the hook passes the edge of the hole, the cantilever beam returns to its original shape. The beam should be tapered from the tip to the base, to more evenly distribute the stress along the length of the beam.

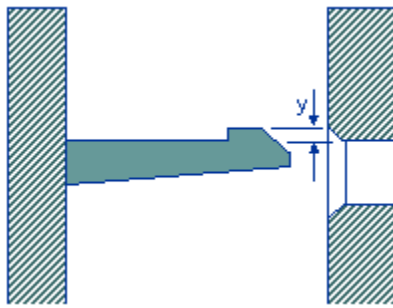

FIGURE 6. Typical cantilever snap-fit joint. The interference between the hole and the hook, y , represents the deflection of the beam as the hook is inserted into the hole.

Proportional limit

Assembly stress should not exceed the proportional limit of the material.

Designing the hook

Either the width or thickness can be tapered (see [Figure 6](#)). Try reducing the thickness linearly from the base to the tip; the thickness at the hook end can be half the thickness at its base. Core pins through the base can be used to form the inside face of the hook. This will leave a hole in the base, but tooling will be simpler and engagement of the hook will be more positive

Designing the base

Include a generous radius on all sides of the base to prevent stress concentration.

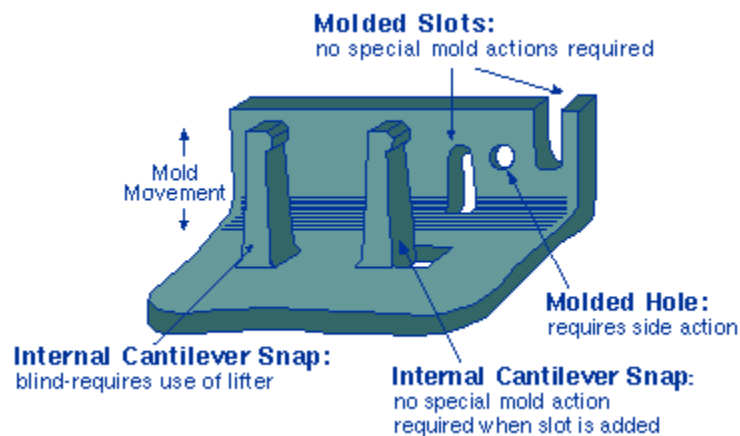

FIGURE 7. Design the snap-fit features for ejection.

Torsion snap-fit joints

In these joints, the deflection is not the result of a flexural load as with cantilever snaps, but is due to a torsional deformation of the fulcrum. The torsion bar (see [Figure 8](#)) is

subject to shear loads. This type of fastener is good for frequent assembly and disassembly.

Design formula

The following relationship exists between the total angle of twist Φ and the deflections y_1 or y_2 :

$$\sin \Phi = \frac{y_1}{l_1} = \frac{y_2}{l_2}$$

where:

Φ = angle of twist

y_1 and y_2 = deflections

l_1 and l_2 = lengths of lever arms (see [Figure 8](#))

The maximum permissible angle Φ_{pm} is limited by the permissible shear strain γ_{pm} :

$$\Phi_{pm} = \frac{180}{\pi} \times \gamma_{pm} \times \frac{l}{r}$$

where:

Φ_{pm} = permissible total angle of twist in degrees

γ_{pm} = permissible shear strain

l = length of torsion bar

r = radius of torsion bar

The maximum permissible shear strain γ_{pm} for plastics is approximately equal to:

$$\begin{aligned} \gamma_{pm} &= (1 + \nu) \epsilon_{pm} \\ \gamma_{pm} &= 1.35 \epsilon_{pm} \end{aligned}$$

where:

γ_{pm} = permissible shear strain

ϵ_{pm} = permissible strain

ν = Poisson's ratio (approx. 0.35 for plastics)

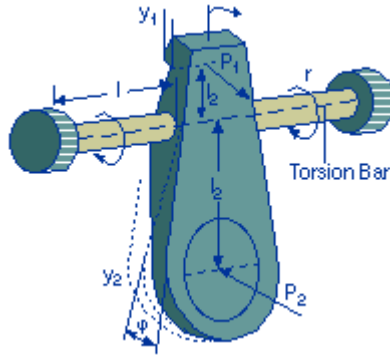

FIGURE 8. Torsional snap-fitting arm with torsional bar. Symbols defined in text above.

Fasteners

Screws and rivets, the traditional methods of fastening metal parts, can also be used with plastics. Several important concerns are:

- Over-tightening the screw or rivet could result in induced stress.
- Threads might form or be cut as the screw is inserted.
- Burrs on the screw head or nut or on the head of the rivet could act as stress risers and cause early failure.

Screws and rivets

Use smooth pan-head screws with generous pads for the head. Washers under the screw or rivet head should be burr-free or the punch-face should be against the plastic (die-face will have burrs from the stamping process). Figure 9 provides recommendations for the diameter of clearance holes for various screw sizes.

Screw Size	Hole Diameter	Hole Diameter
	(in.)	(mm)
#2	.096	2.44
#4	.122	3.10
#6	.148	3.76
#8	.174	4.42
#10	.200	5.08
#12	.226	5.74
1/4	.260	6.60
5/16	.323	8.20
3/8	.385	9.78

FIGURE 9. Recommendations for clearance between the machine screw and hole in the plastic. The pan-head style of the screw is recommended.

Use	If
Thread-forming screws: ASA Type BF	The modulus of the plastics is less than 200,000 psi
Thread-cutting screws: ASA Type T, (Type 23) or Type BT (Type 25).	The modulus is greater than 200,000 psi, since thread-forming screws can cause stress cracking in this case
A metal, threaded cap with one screw thread on the boss.	The screw is to be removed and replaced many times. This will assure that later insertions do not cut or form a new thread, and destroy the old one.
Counter-bore hole with pan-head screw	The screw head must be below the surface of the part.
Rivets to join plastic parts for a permanent assembly	The design prevents over-tightening of the joint or washers are used to prevent the head from cutting into the plastic.

Do not use	Since
Countersunk screw heads	They are easily over-tightened and cause stress-cracking.
Pipe threads	The tapered nature of this thread style can allow the joint to be easily over-tightened and over-stressed. Stress-cracking will result

Molded threads

Molding threads into the plastic component avoids having to use separate fasteners such as screws and rivets. If the threads are molded, tool-making will be easier if you provide a lead-in diameter slightly larger than the main diameter and about one screw flight long. [Figure 10](#) shows how to design an unthreaded lead-in.

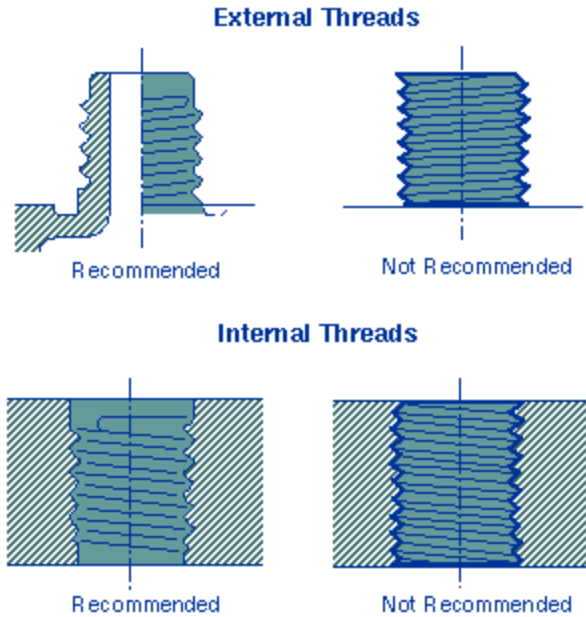

FIGURE 10. Recommended design for molded threads.

Below are some guidelines to designing molded threads:

► **Thread size**

Threads should be strong enough to meet the expected loads. Threads that are too small, especially if they're mated with metal threads, tend to become deformed and lose their holding power.

► **Inside radius of the thread**

The thread design should avoid sharp inside radii. The corollary is that the peak of the thread should also be rounded to ease tool making.

► **Orienting threads to the parting line**

If the axis of the thread is parallel to the mold parting line, half of the diameter can be molded in each mold half. You can reduce the effects of the parting line mismatch by partially flattening the threads at that point. Retractable mold components must be used if the axis of the threads is not parallel to the parting line.

► **Demolding the threads**

Internal threads usually require un-screwing the mold component from the part, either manually or by action of the mold. Large internal threads can be formed on collapsing mold components.

Inserts

An *insert* is a part that is inserted into the cavity and molded into the plastic. The insert can be any material that will not melt when the plastic is introduced into the cavity. Metal inserts are used for electrical conductivity, to reinforce the plastic, and to provide metal

threads for assembly. Plastics inserts can provide a different color or different properties to the combinations.

Balancing melt flow

Place the gate so that equal melt flow forces are placed on opposing sides of the insert. This will keep the insert from moving or deforming during mold filling. Design adequate flow paths so that the melt front proceeds at the same rate on either side of the insert.

Support posts

Design support posts into the mold (these will be holes in the part) to support the insert.

Shrinkage and weld lines

Allow for shrinkage stress and for the weld line that will typically form on one side of the boss around the insert.

Welding processes

Ultrasonic welding uses high-frequency sound vibrations to cause two plastics parts to slide against each other. The high-speed, short-stroke sliding between the two surfaces causes melting at the interface. When the vibrations are stopped, the melted interface cools, bonding the two surfaces. Other welding processes are generally not reliable or involve considerable hand work.

Design rules for welding

- The two materials must be melt compatible.
- The design of the ultrasonic horn that transfers energy to one of the plastics parts is important to success.
- Design axis-symmetrical parts with an interference at the joint. This is melted and the parts are forced together.
- The design of the contact surfaces is critical to success. You'll need to design an energy director, a small triangular raised bead, on one of the faces to be welded.

